

SPKL O AL 70

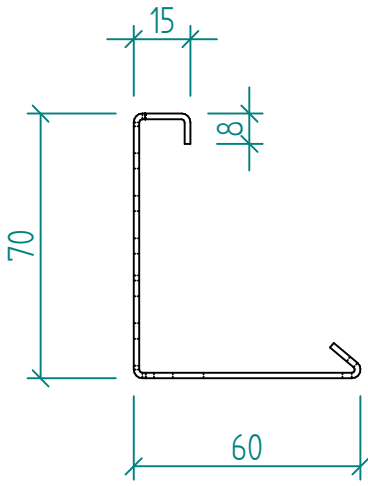

1:2

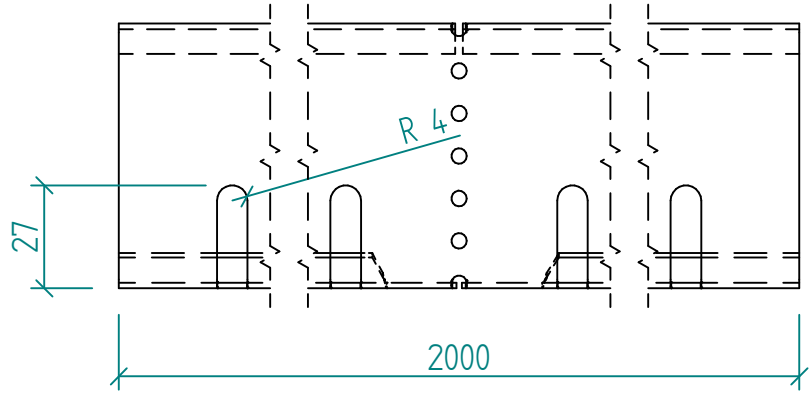

1:5

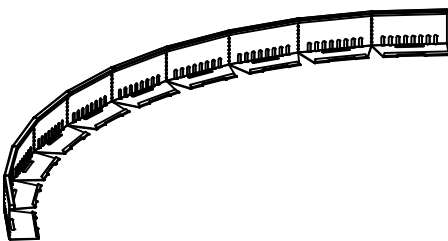
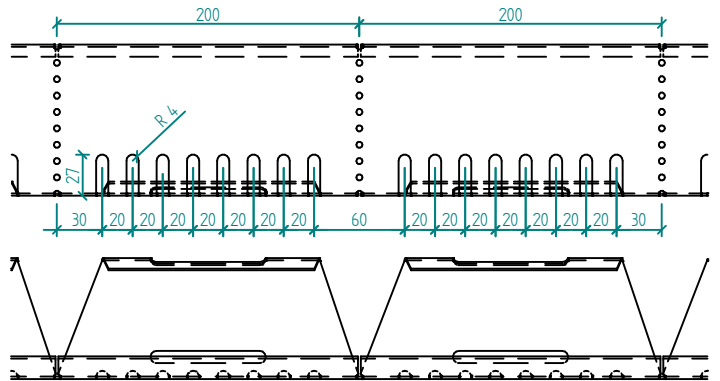

SP PROFIL

Název	Code	Materiál	Hmotnost	Tloušťka materiálu
SPKL O AL 70	020305_070_OAL15	Hliník AW 1050	1,077 kg	1,500 mm